

# BTI'S BUTTERFLY VALVE STEM EXTENSION VS. THE COMPETITION

# THE **BTI** DIFFERENCE

The industry's **only** Direct Drive Stem Extension Solution that is Stronger, Lighter and American Made.

## STRONGER

BTI's stem extension yielded 450 ft. lbs. of torque while the competition's model failed at 250 ft. lbs.

## DIRECT DRIVE REQUIRING NO COUPLERS

BTI's direct drive provides greater strength and virtually eliminates slop. The competition's solution has two added connection points causing excessive slop, built-in fatigue and stress points. Also, BTI uses no stem adapter like used on the competitor's model resulting in a reliable, stable and strong extension.

## LIGHTWEIGHT

Our 5" BTI MaxxLife valve with an 18" extension weighed in at 12.80 lbs. vs. the competitor's 5" model with an 18" extension weighing 13.95 lbs. Put that same extension on a BlackMaxx Composite Valve and the weight drops to 11.85 lbs., that's a 15% reduction in weight!

## EXTENSION HOUSING

BTI's fully supported shaft provides added strength over the competition's model. Our enclosed design, with o-ring seals top and bottom, eliminates contamination while the competitor's model is open to the elements, leading to accelerated corrosion and seizing of valve.

## LUBRICATION POINT

BTI's built-in grease fitting adds reliability and virtually eliminates valve seizures, increasing your valves life!

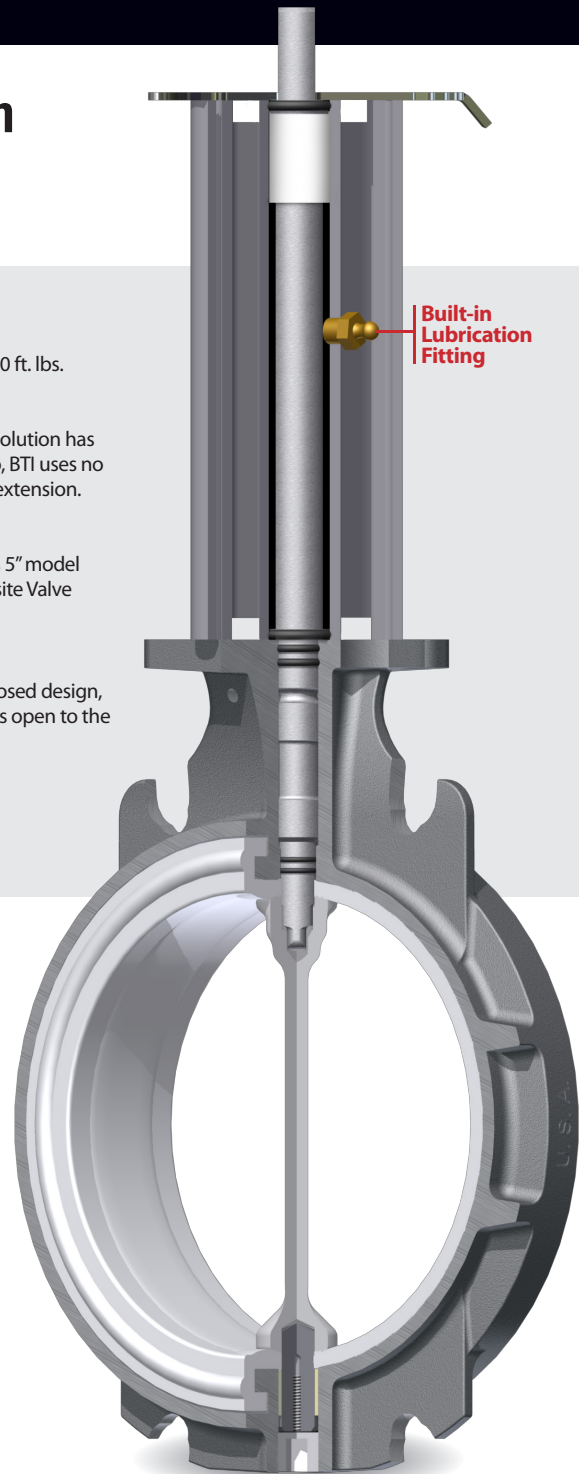

	BTI EXTENSION	COMPETITOR
<b>80% Stronger</b>	✓	✗
<b>No Coupling Required</b> Patented Direct Drive One-Piece Stem	✓	✗
<b>Lightweight Design</b>	✓	✗
<b>Fully Supported Shaft</b>	✓	✗
<b>Built-in Grease Fitting</b>	✓	✗
<b>Better Corrosion Protection</b>	✓	✗



Better Through Innovation



All BTI products are guaranteed to  
**LAST LONGER. WORK BETTER.**  
**1-800-841-5524 • BulkTankInc.com**

©2016 Bulk Tank, Inc. • U.S. Patents Pending